



Barista Hot & Ice Coffee  
With Fresh Milk

PREMIUM  
**JL852 SERIES**

Jetinno Fresh Milk Coffee Vending Machine

# Enjoy Your Bean Go Time

Jetinno Chief Expert Counselor  
**JORIS HENDRIKS**

Owner of 5 invention patents

Founder of Hendriks Coffee

High-end coffee machine designer

7 years in Spengler as product manager and corporate partner

15 years in Maas International as product designer and R&D manager

A portrait of Joris Hendriks, a middle-aged man with short, graying hair and glasses. He is wearing a teal V-neck sweater over a dark blue collared shirt. The background is dark, and there is a pile of coffee beans at the bottom left. A white signature is visible on the bottom left of the image.

*Joris Hendriks*

# CONTENTS

- Product Highlights
- Product Features
- Core Components
- Product Parameters
- Product Size
- Optional Parts
- Customization Details
- Clean Products
- Product Certificates
- Our Services





# Integrated to Make Excellence

## Powerful And Stable Hot Water System

Equipped with 2 water boilers and a vane pump, provides constant temperature and pressure to ensure the extraction quality, and continues hot water to shorten refilling time. Productive and efficient.

## Smart Hot & Ice Fresh Milk System

Built with Fluid-o-Tech milk pump and a separate steam boiler, produces hot&cold milk and milk foam, able to set the humidity and temperature for each cup. Support milk remaining detection, milk shortage warning, and automatic milk pipeline cleaning.

## Modular Design

Diversity of configurations are available by choosing different brewing modules and instant modules.



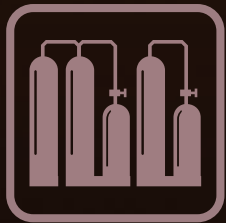

3 Boilers

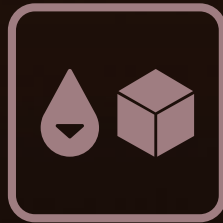

Integrated  
Ice/Cold Water



Hot/Cold  
Milk Foam



Auto Capping



Syrups

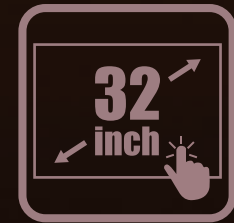

32" Touch Screen



40+drinks



Flavors Milk Coffee



ES Extraction



Auto Cleaning



Fast Production



Quick Refill



# Exceptional Quality Derives from Profession

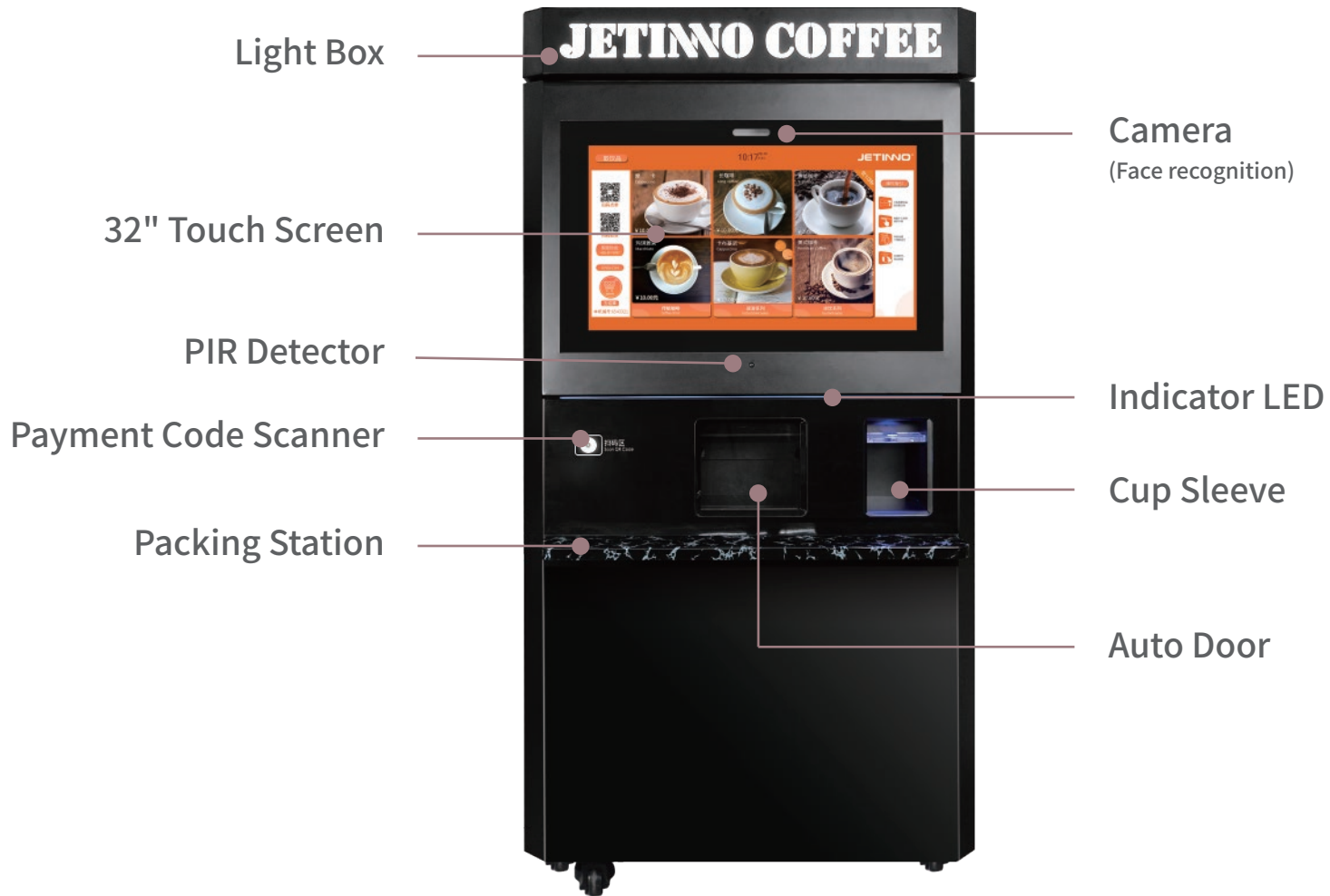

# Sleek Outside, Solid Inside

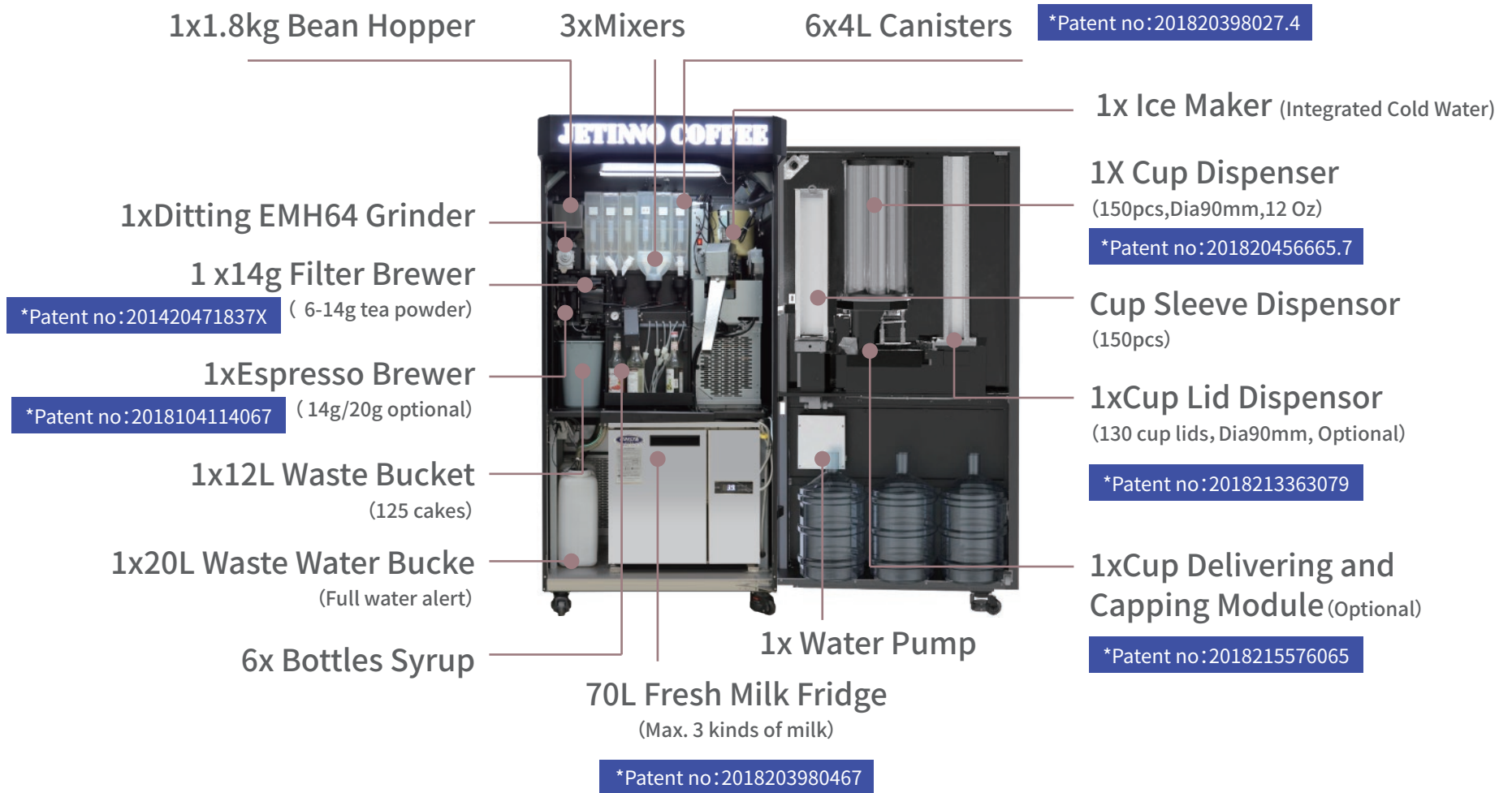



## Smart, Automatic and Friendly

Function as an intelligent coffee house with human detection and auto ads, a 32" touch screen and intuitive user menu, flexible payment methods, automatic cup dispensing/capping and packing station.

## 40 + Drinks, Diversed Flavors

JL852 is capable to serve with more than 40 beverages, varied by hot/cold/ice drinks, fresh coffee/fresh tea/fresh milk/instant drinks, and different syrup flavors.





## Premium Drink Quality and Taste

Equipped with Ditting EMH64 grinder, Jetinno Patent Brewer and professional hydraulic system to ensure perfect extraction of bean, and hot/cold fresh milk foam system to provide smooth and dense milk foam.

## Fast Production and Refilling

Equipped with 2 water boilers to provide constant temperature continues hot water, reducing the waiting time for drinks.

## Details Make Professional



### Hygiene Improvement

Well-sealed waste bucket  
Prevents pollution and smell.



### Bigger Space for Barrels

Able to store 3 barrel water.



### Multiple Payment Methods

QR code scanner, card reader and  
many other payment ways.



### Cup Sleeve Dispenser

Drop 1 pcs cup sleeve for  
each cup of drinks.

## Exceptional Quality Derives from Profession



### Start-up Cleaning

The machine will automatically make full machine cleaning every time it is powered on.



### Regular Cleaning

Schedule a time and the machine will conduct an auto full-machine cleaning.



### Milk System Cleaning

Schedule a time and the milk system is able to have auto cleaning, removing the milk dregs and residue.



### Partial Cleaning

Choose to separately clean key modules.



### Deep Cleaning

Use exclusive cleaners to deeply clean coffee and milk residue.



### Manual Cleaning

Manually remove the module or parts and deeply clean by hand.

# Jetinno SaaS Management

Support PC and mobile



## Remote Control

Support remote control of recipes adjustment, machine setting, UI ads and video upload, machine system upgrade.

## Malfunction Alert

Real time machine malfunction alert, can push notice to machine operator.

## Comprehensive Data

Location deployment data, drink sale data, payment data, all these data statistics help operator better in machine operation and coffee vending business.



## Powerful Machine Console Platform



● Drink Promo Tag Setting

● Drink Sale Report

● Ads Management

● Stock Management

● Drink Data Bank

# Modular Design

The combination of modules has been fully considered in the design stage, and the beverage production modules such as coffee extraction module and instant module are flexibly combined into one machine to facilitate customers to put into different scenarios to meet user beverage needs.



## Jetinno Patented Hydraulic System

- 2700W heating power, continuous and stable water temperature guaranteed.
- Sweden Backerths 700ml stainless high-pressure boiler, max 25bar tolerance.
- USA EMERSON professional STB temperature control protective switch.
- Japan OMRON temperature/pressure sensor, real-time monitoring.
- Italy ULKA high -pressure electromagnetic pump, provides 9Bar extraction pressure.
- Other valve joints spare parts, flow meter are all Italy and German made.



## Jetinno Smart Milk Foam System

- Provide hot/cold Milk and hot/cold milk foam.
- Fluid-o-tech milk pump, makes dense and silky foam.
- Smart detection, milk tank empty alert.
- humidity and temperature settings for each drink.
- milk system auto cleaning.
- separate and detachable fresh milk module.

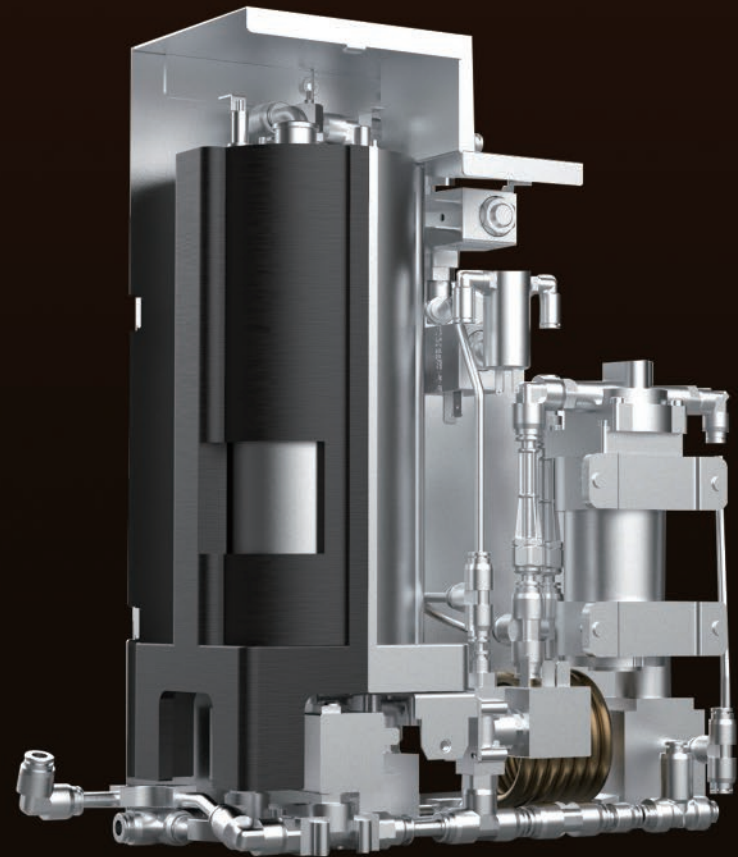



## Ice Maker

- Jetinno patent.
- Built-in weighing device, precise control of ice production, ice empty detection.
- Brazil Embarco compressor, Japan evaporator, stable and effective.
- 1.5kg/bucket ice storage volume, daily ice production of 72kg/day.
- Can manually cleaning, with UV light inside, keep hygiene.
- Intelligent detection of ice full, ice lack detection and over cooling malfunction.

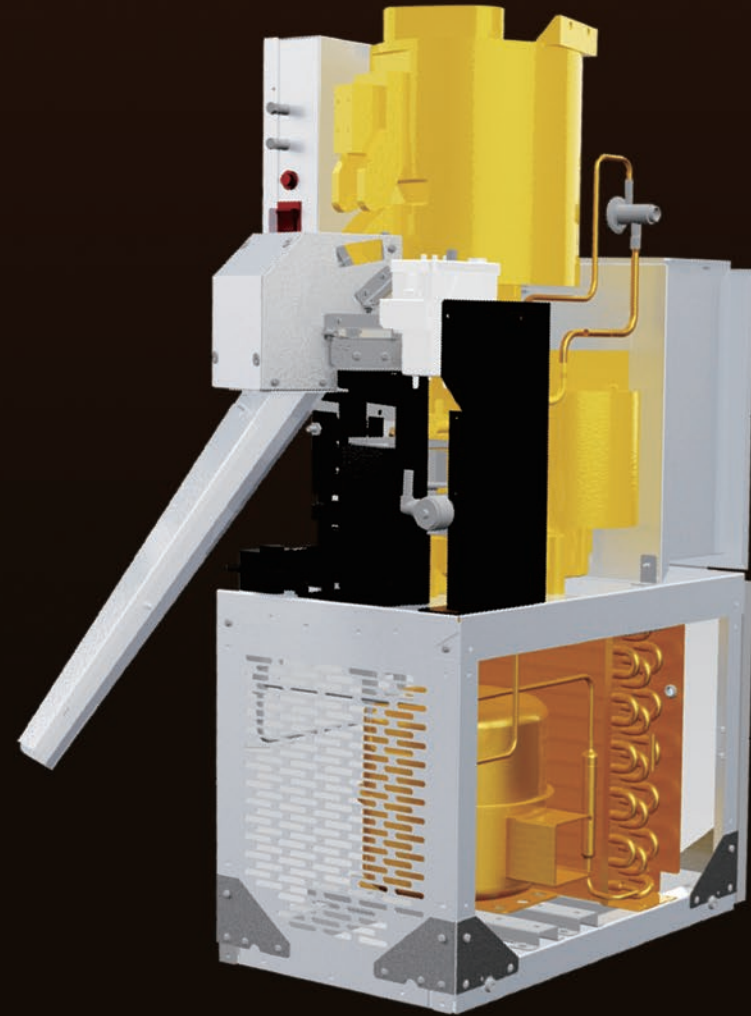

## Ditting EMH64 Grinder

- 64mm flat bur, made of stainless steel.
- Low grinding heat, no interference to coffee flavor.
- Multiple adjusting grades of grinding fineness.
- 125,000 times lifespan, long service life.

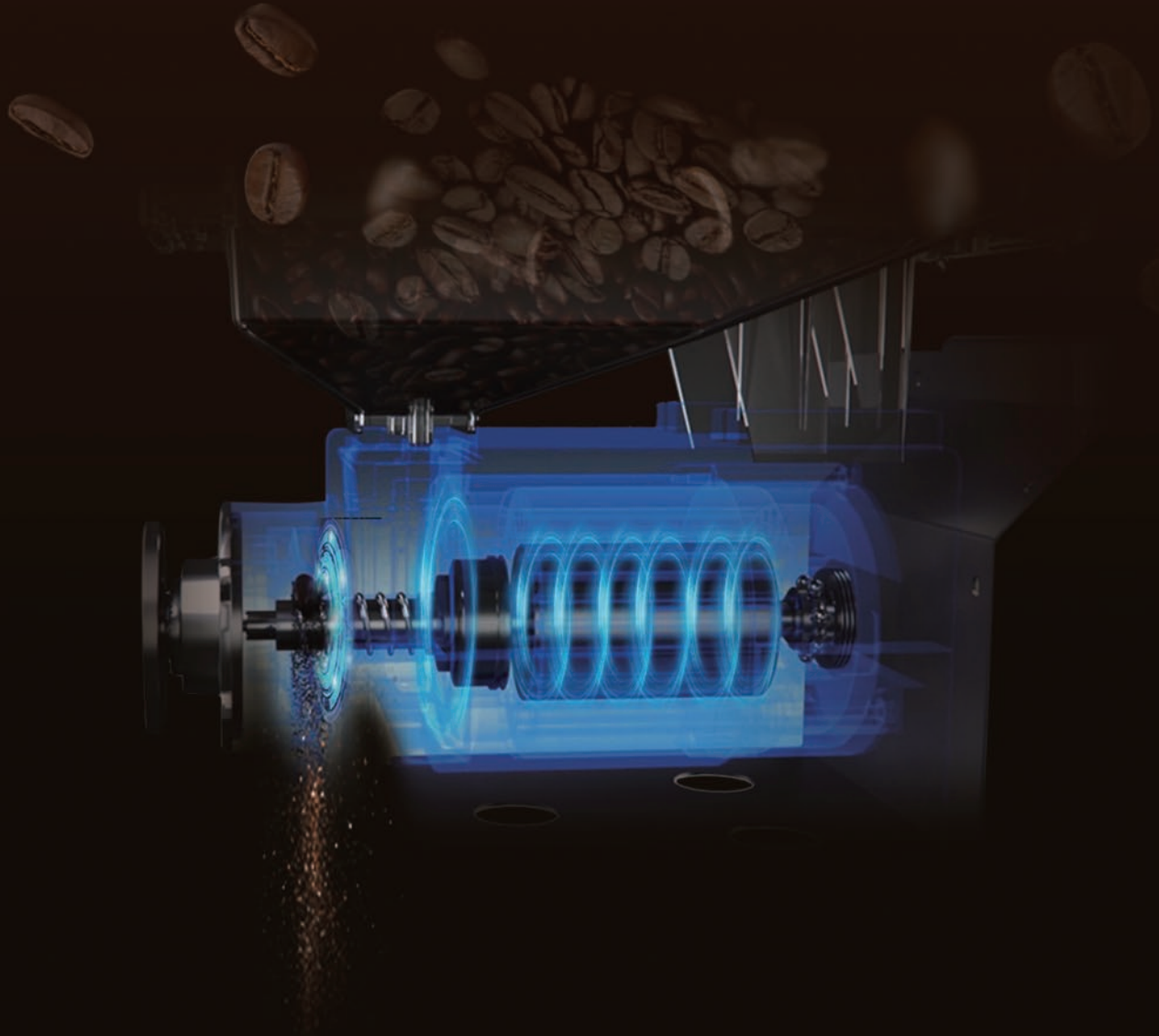

## Professional Coffee Brewing System

- Removable brewer module design, easy for cleaning.
- 9bar 92°C Espresso extraction, compatible with low-pressure brewing.
- Jetinno PTC international patent, European time-honored brand applies the same type.
- Pre-infusion function to have saturated extraction.
- PTC heaters in brewing chambers, provide constant heating to solve low-temp of first cup.
- Built with 14g and 20g two brewing chambers, for different recipes.
- Detachable brewing chamber design, easy for deep-cleaning.

PTC  
Heater

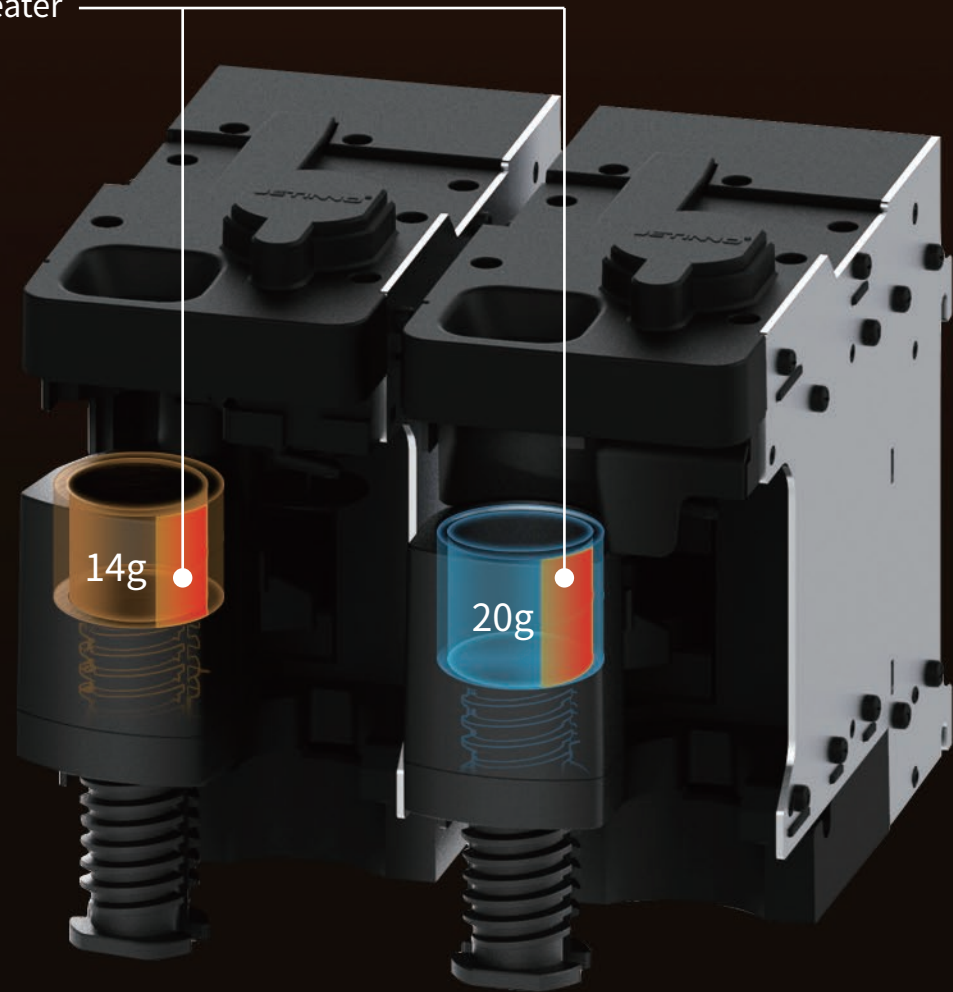

## Filter Brewer(for coffee & tea)

- Jetinno patent.
- Spraying and pre-infusion, better extraction.
- Adjustable brewing time, water temperature and water dose.
- Detachable components design, convenience of cleaning.
- Direct coffee powder dropping, no secondary pollution.
- Maximum 14g coffee or tea powder loading.
- Can be used both as coffee and tea brewer.





## High Speed Mixing System

- Patented tech innovated by Jetinno.
- Detachable mixing chamber, easy for cleaning and maintenance.
- Up to 20000rpm stirring speed, rapid sufficient dissolution.
- Adjustable stirring speed for different recipes.  
( milk foam requires high speed, instant coffee and tea drinks require low speed).

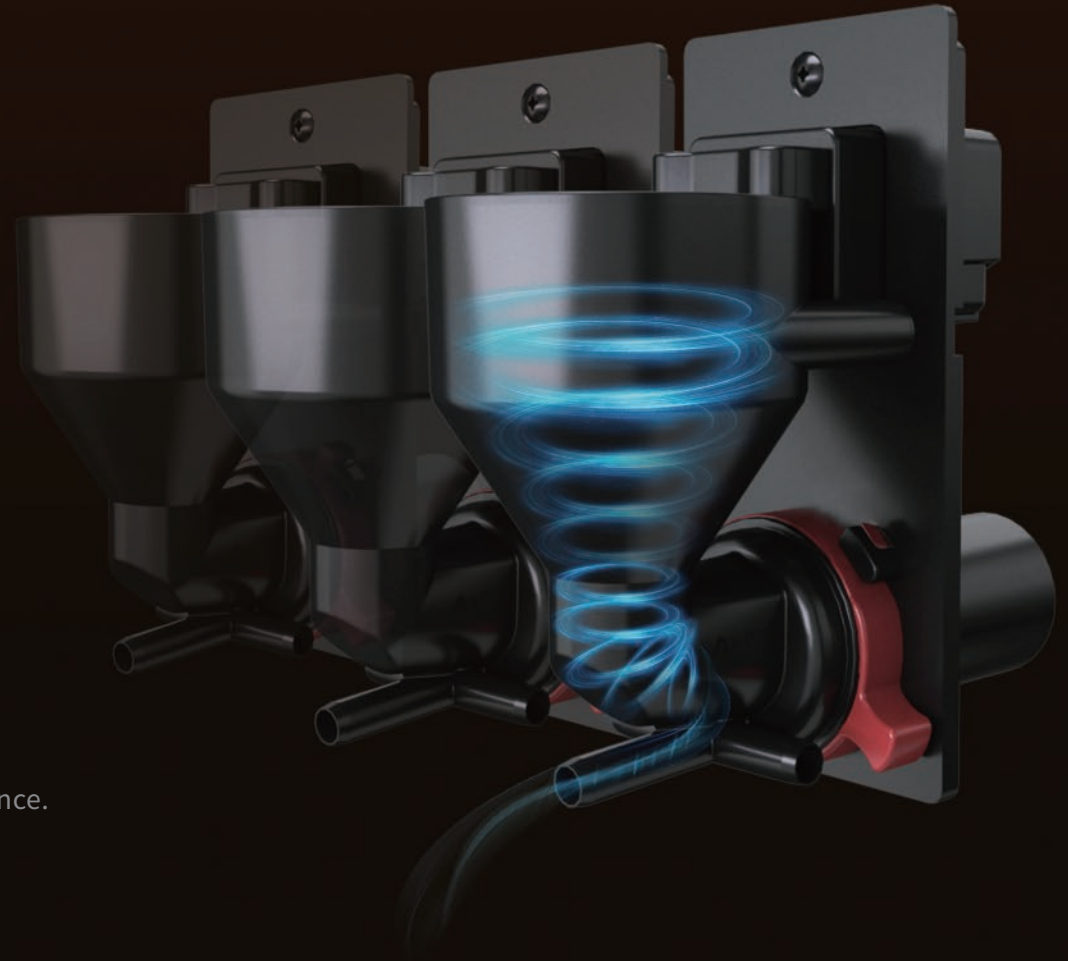

## Syrup Station

- Module size: 180mm W, 400mm H, 500mm D.
- Slider holder, easy in and out for refill.
- 6pcs high accuracy peristaltic pump through counting to remind empty.
- Max 6 bottles of syrup (OD of bottle is 80mm, height is 315mm).



## Cup Dispensing

- D90mm, 12/16 Oz.
- Smart cup dispensing with 5 columns.
- Real time cup status monitoring.

## Cup Lid Dispensing

- D90mm, cup lid auto dispensing.
- Cup lid status monitoring.

## Cup Lid Capping

- Auto cup lid capping.
- Real time cup lid quantity.
- monitoring and empty warning.



## Multi-function main board

- Designed and developed by Jetinno.
- 8 core Cortex A7 CPU, 2GHz.
- Multiple network ports for network connection.
- Multiple displaying format ports and dual screen displaying.
- Up to 10-way ports expansion.
- Android & Linux.

## IO board

- Designed and developed by Jetinno.
- Quick response.
- Fast protection for malfunctioned unit.
- Precisely control all module units.
- Multiple ports expansion, can independently support 25-way control unit.
- Support various types of sensors, including temperature, humidity, flow and pressure.

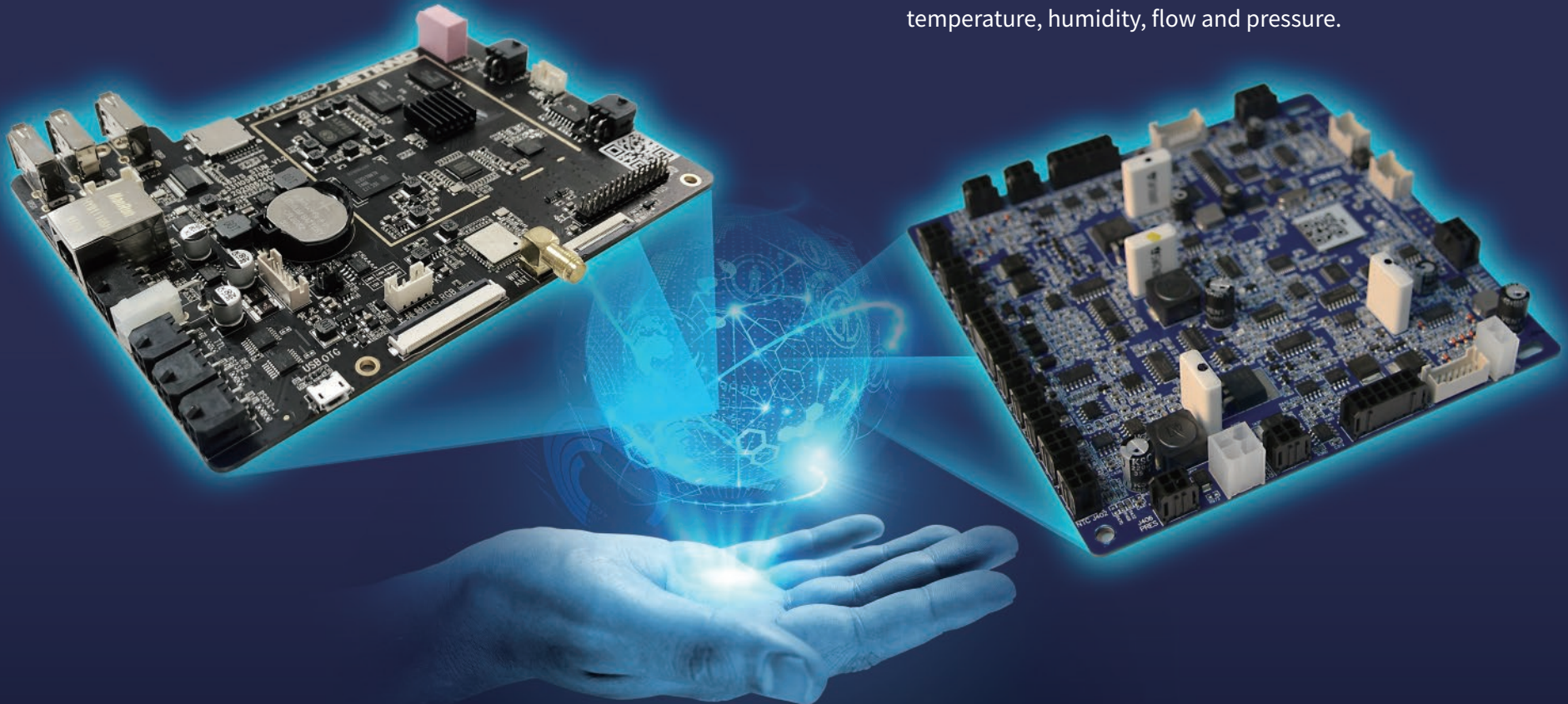

The logo for Ditting, featuring the word "ditting" in a bold, lowercase sans-serif font, with "SWISS" in a smaller, uppercase sans-serif font centered below it. The text is flanked by two horizontal lines above and below.

Switzerland Ditting Grinder

The logo for Fluid-o-Tech, featuring a stylized circular icon on the left composed of concentric lines and a central vertical element. To the right of the icon, the text "Fluid-o-Tech" is written in a bold, sans-serif font, with "POWER THE FLOW" in a smaller, uppercase sans-serif font below it.

Italy Fluid-o-tech Pump



Sweden Backerhts boiler

The logo for AVS-Römer, featuring a stylized, bold, black letter "A" above the text "AVS-Römer" in a bold, sans-serif font.

German AVS Römer joints



Italy ODE valve bank

The logo for Embraco, featuring the word "embraco" in a bold, lowercase sans-serif font.

Brazil Embraco Ice Maker





Configuration	JL852I-2ES7C6S-FM-Y	JL852I-ESFB7C6S-FM-Y
Bean Hopper	1x1.8kg+1x1.0kg	1x1.8kg
Instant Container	5x4.0L	6x4.0L
Grinder	2xDitting EMH64	1xDitting EMH64
Espresso Brewer	1x14g/20g	1x14g/20g
FB Brewer	/	1x14g (Tea)
Mixer	3	3
Hot Water Boiler	1x700mL, 2700W+1x700mL, 1800W	1x700mL, 2700W+1x700mL, 1800W
Steam Boiler	1x700mL,3000W	1x700mL,3000W
Integrated (Ice/Cold Water)	✓	✓
Hot/Cold Fresh Milk System	✓	✓
Fresh Milk Fridge	✓	✓
Syrup Module	Maximum 6 bottles	Maximum 6 bottles
Waste Bin	✓	✓
Waste Water Bucket	✓	✓
Auto Cup Dispenser	✓	✓
Cup Lid Capping Module	✓	✓
Cup Delivery Door	✓	✓
Cup Holder Dispensor	Optional	
Waste Water Drainage	Optional	
Top Light Box	Optional	
Water Supply	Tap water(default), barrellled water(optional)	
Internet Connection	WiFi (default) 4G (optional)	
Payment System	Standard-wechat or alipay/Optional-scanner pay or other MDB payment devices	
OS	Android	
SaaS Platform	Optional	

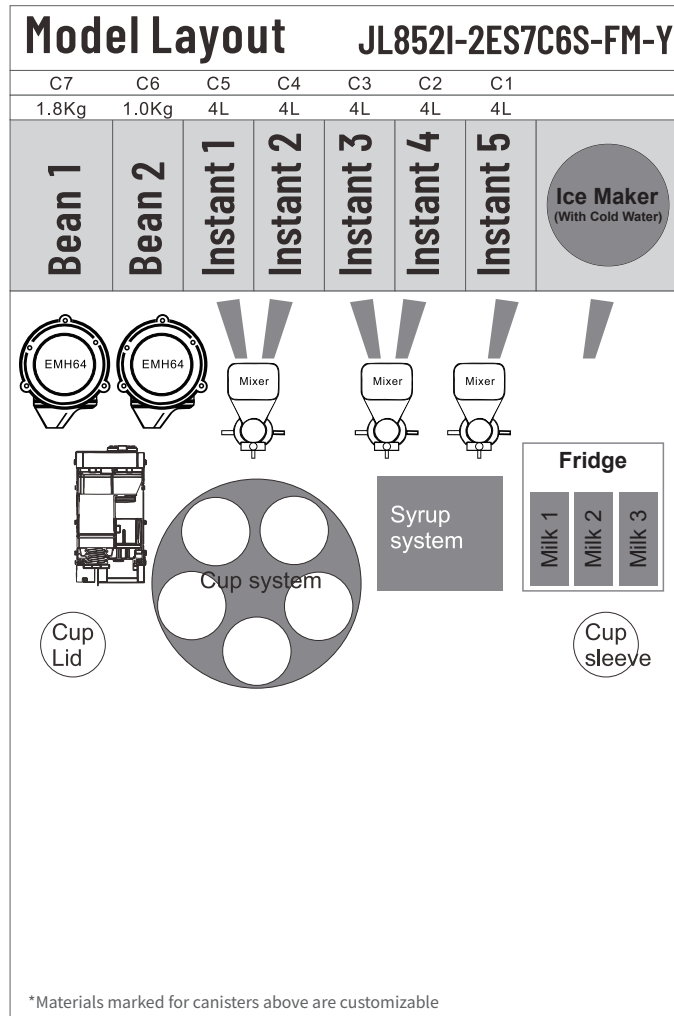

Configurations	Parameter specification
Displaying Screen	32" touch screen
Bean Hopper	1x1.8kg+1x1.0kg
Instant Canister	5x 4.0L
Grinder	2xDitting EMH64
Espresso Brewer	1x14g/20g
Mixer	3
Hot Water Boiler	1x700mL, 2700W+1x700mL, 1800W
Steam Boiler	1x700mL, 3000W
Waste bin	125 cakes
Waste Water Bucket	20L,full detection function
Cup	D90mm 16 Oz (Optional 12 Oz)
Cup Lid	D90mm
Water Supply	Tap water(default), 3xbarrelled water(optional)
Power Supply	220-240V 50/60Hz
Rated Power	3800W
Dimensions (W*H*D)	1000*1900*1000mm
Net Weight	450kg
Main Drinks : Espresso, American coffee(ice / hot), Cappuccino (ice / hot), Latte (ice / hot), Mocha (ice / hot), Milk, Cocoa, Fruit juice (cold)	

**Daily Output:**  
**250 Cups/Daily**

**Production time**

Espresso: 45 Seconds/cup	American coffee: 65 Seconds/cup
American coffee(ice): 90 Seconds/cup	Cappuccino: 95 Seconds/cup
Instant: 50 Seconds/cup	

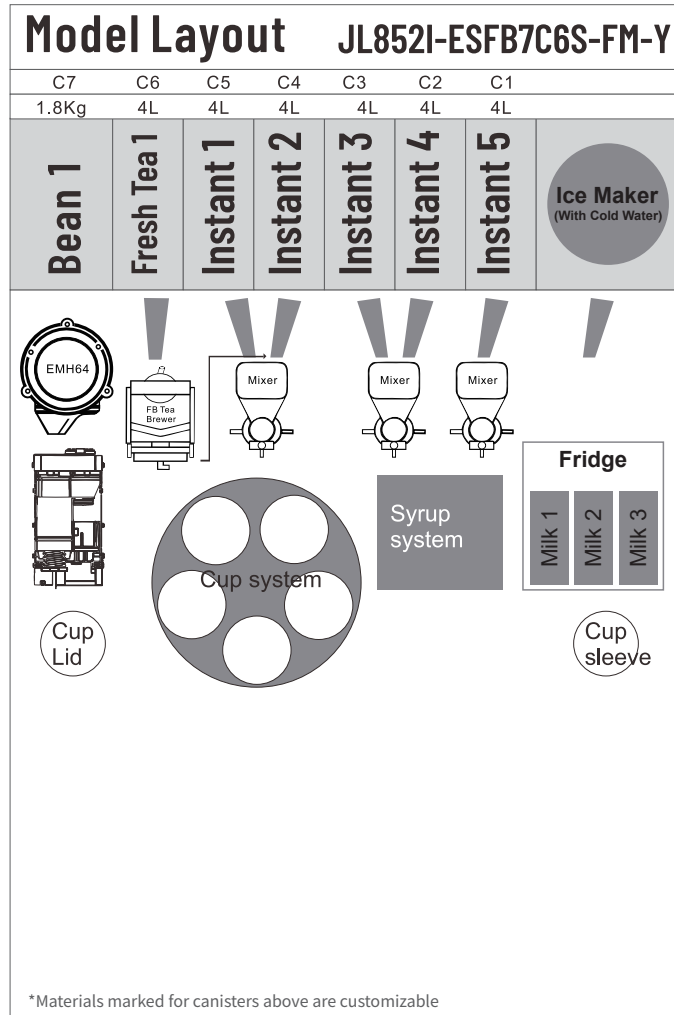

Configurations	Parameter specification
Displaying Screen	32" touch screen
Bean Hopper	1x1.8kg
Instant Canister	6x 4.0L
Grinder	1xDitting EMH64
Espresso Brewer	1x14g/20g
Drip Brewer	1x14g (Tea)
Mixer	3↑
Hot Water Boiler	1x700mL, 2700W+1x700mL, 1800W
Steam Boiler	1x700mL, 3000W
Waste Bin	125 cakes
Waste Water Bucket	20L,full detection function
Cup	D90mm 16 Oz (Optional 12 Oz)
Cup Lid	D90mm
Water Supply	Tap water(default), 3xbarrelled water(optional)
Power Supply/Rated Power	220-240V 50/60Hz 3800W
Dimensions (W*H*D)	1000*1900*1000mm
Net Weight	450kg
Main Drinks : Espresso、American coffee(ice / hot)、Cappuccino (ice / hot)、Latte (ice / hot)、Mocha (ice / hot)、Milk、Cocoa、Fruit juice (cold)、red tea	

**Daily Output:**

**250 Cups/Daily**

**Production time**

Espresso : 45 Seconds/cup	American coffee : 65 Seconds/cup
American coffee(ice) : 90 Seconds/cup	Cappuccino : 95 Seconds/cup
Instant : 50 Seconds/cup	

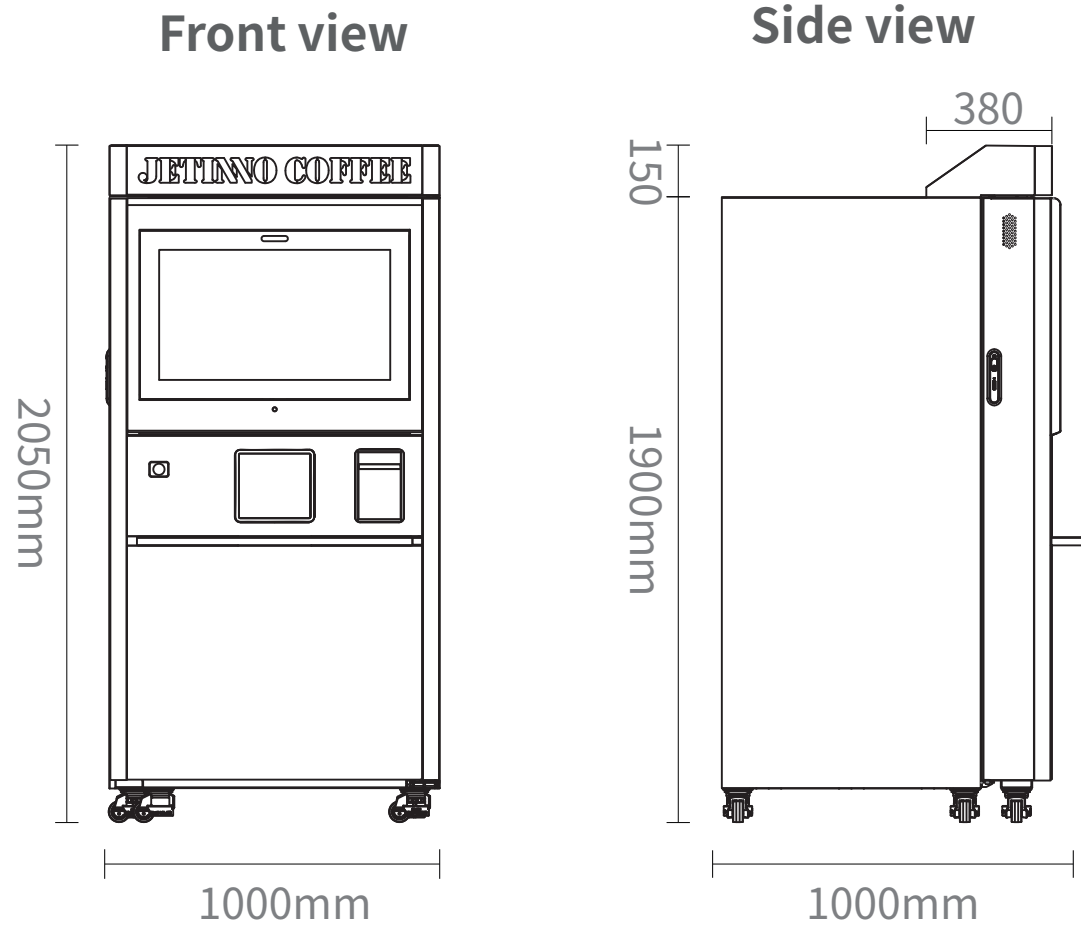

Package Dimension(Coffee Machine) :1100 (W) \*1100 (D) \*2030 (H) mm

Package Dimension(Light Box):1050 (W) \*420 (D) \*200 (H) mm



Optional Module	Optional or Not
UV Light	Optional
Electric Meter	Optional
4G Card	Optional

Payment Module	Optional or Not
Facial Scan Payment	Optional
Reverse QR Code Payment	Optional
Bill Validator	Optional
Coin Validator	Optional
RFID Payment	Optional
MDB Cashless	Optional



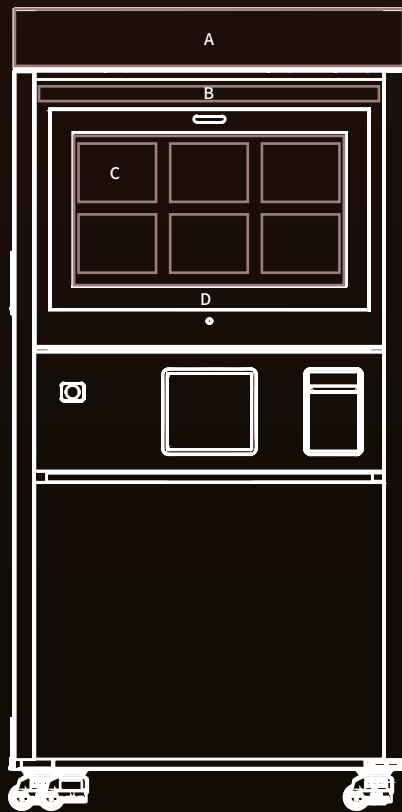

## UI customization

Name	Position	Width	Height	Format
Light box	A	6500mm	1840mm	AI or cdr
Brand LOGO	B	200mm	75mm	AI or cdr
UI drink picture	C	316PX	360PX	PNG
Video ads	D	1920PX	1080PX	PNG

## Deep customization

Name	Item
Ports	Open communication protocol, support customer self-developed APP.
	Open network interface(TCP/IP), support customer self-developed server.
	Open RESTful interface, support customer online store and data system.
OS	APP application layer customizable development (Android).



Product: Coffee machine tea brewer cleaner  
 Use: used for coffee machine tea brewer cleaning  
 Ratio: 2 pills with 5.67L water  
 Details: 4g/pill, 120 pills/bottle, 12 bottles/case



Product: coffee machine boiler cleaner  
 Use: used for coffee machine boiler cleaning  
 Ratio: 200g powder with 3.9L water  
 Details: 1kg/bottle, 6 bottles/case



Product: coffee machine cleaner  
 Use: used for coffee machine brewer cleaning  
 Details: 2g/pill, 100 pills/can, 12 cans/case



Product: cleaning brush  
 Use: used for coffee machine cleaning and maintenance  
 Details : general use



Product: tower  
 Use: used for coffee machine cleaning and maintenance  
 Details : general use



### Security Certification



### Food Contact Material

EU 1935/2004  
European food test

Europe

LFGB  
German



US

GB  
GB4806  
China

### Europe EVA energy consumption level A

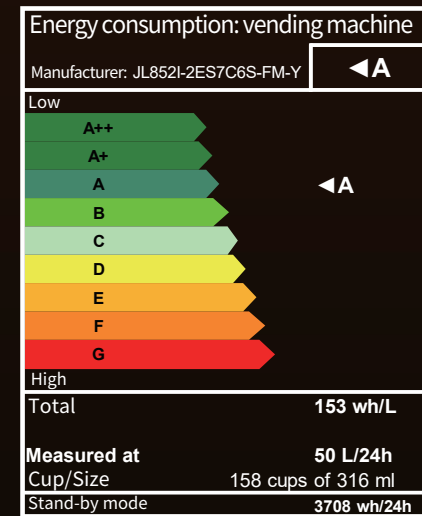

95% Recycled

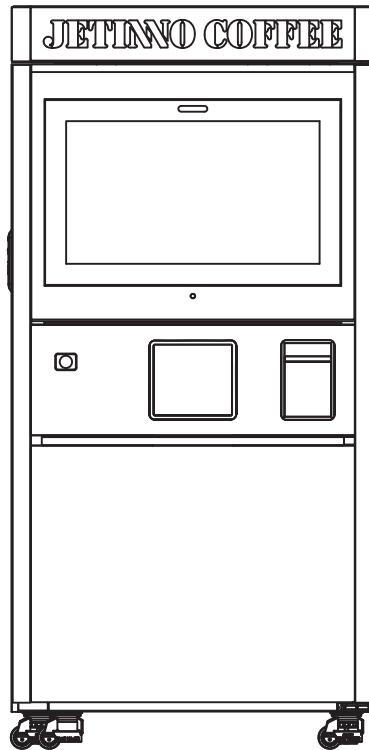

Guangzhou Jetinno Intelligent Equipment Co., Ltd

Address: 4F, No. 2, Ruitai Road, Huangpu District, Guangzhou, China

Tel: 400-017-9997

E-mail: [inquiry@jetinno.com](mailto:inquiry@jetinno.com)

Website: [www.jetinno.com](http://www.jetinno.com)

[www.jetinnovending.com](http://www.jetinnovending.com)